

## DESCRIPTION OF PARTS

The LED light bar can be installed easily using magnets or mounting clips.

## TECHNICAL DATA

NAH-12NW7 24V DC 12W 4000K  
NAHE-12NW7 24V DC 12W 4000K  
NAHR-12NW7 24V DC 12W 4000K  
NAH-12WW7 24V DC 12W 3000K  
NAHE-12WW7 24V DC 12W 3000K  
NAHR-12WW7 24V DC 12W 3000K

NAH-4NW7 24V DC 4W 4000K  
NAHE-4NW7 24V DC 4W 4000K  
NAHR-4NW7 24V DC 4W 4000K  
NAH-4WW7 24V DC 4W 3000K  
NAHE-4WW7 24V DC 4W 3000K  
NAHR-4WW7 24V DC 4W 3000K

NAH-8WNW7 24V DC 8W 4000K  
NAHE-8WNW7 24V DC 8W 4000K  
NAHR-8WNW7 24V DC 8W 4000K  
NAH-8WW7 24V DC 8W 3000K  
NAHE-8WW7 24V DC 8W 3000K  
NAHR-8WW7 24V DC 8W 3000K

## LED LIGHT

Protection class III

The LED light agent cannot be replaced.

## RECOMMENDED LED DRIVER

Order Nr.	12W model:	TRL-13W24L
	8W model:	TRL-13W24L
	4W model:	TRL-6W24U

**Do not exceed a combination of 55W (TRLN-50W24) when connecting the light bars to other light bars.**



Protection class III



Notification of Risks



CE label



Safety Instructions



The product is only for use in interiors.



Cleaning Instructions



The product may not be disposed of in the household garbage.



ETL label

## DISPOSAL

The packaging consists of environmentally friendly materials. Dispose of them in the local recycling containers.



Do not dispose of this product in the household garbage when it has reached the end of its lifecycle, but rather take it to a disposal center. Your local officials will provide you with information about collection offices and their business hours.

## SAFETY



READ THE INSTRUCTIONS BEFORE USING THIS PRODUCT. KEEP THE SAFETY AND OPERATING INSTRUCTIONS FOR FUTURE USE.



- The light is only suitable for use in interiors, in dry, enclosed rooms.
- The light is not suitable for fastening on uneven surfaces. Otherwise, the light may fall. The consequences may be damage to the product and/or injury.



- This light bar may not be bent during installation.
- This light bar may not be used on heated surfaces.
- **The performance of 55W when connecting light bars to each other may not be exceeded.**



- The connection may not be made while the lights are turned on.
- The product must be installed according to the instructions.
- Only specialists may do the installation work.
- Do not use the product when it has been damaged (defective covers) or there are operational faults such as flickering, smoking, steaming, crackling noises or the smell of smoke.
- A damaged product may only be repaired or replaced by the manufacturer, their service representative or comparable service personnel.
- The product must be installed according to the validly applicable and country-specific guidelines including VDE 0.100.
- Never open one of the electrical operating agents or plug any objects into them. Such procedures signify a danger to life through electrical shock.
- Absolutely avoid contact between the product and water or other liquids. For reasons of electrical safety, the light may not be placed in contact with water or other liquids or submerged in water.
- The product may not be changed or modified.

## MAINTENANCE AND CLEANING

The LED light agent cannot be replaced.



- Do not use solvents, such as benzene and similar agents. The light would be damaged thereby.
- Only use a dry, lint-free cloth for cleaning the product.

# NAHOO

LED WALL OR CEILING MOUNTED LUMINAIRE

NAH-12NW7/NAH-12WW7  
NAHE-12NW7/NAHE-12WW7  
NAHR-12NW7/NAHR-12WW7  
NAH-8NW7/NAH-8WW7  
NAHE-8NW7/NAHE-8WW7  
NAHR-8NW7/NAHR-8WW7  
NAH-4NW7/NAH-4WW7  
NAHE-4NW7/NAHE-4WW7  
NAHR-4NW7/NAHR-4WW7



anodized aluminium



## INTENDED USAGE

This product will only serve the purpose of illumination.

The light is only suitable for use in interiors, in dry, enclosed rooms.

## SCOPE OF DELIVERY

- 1 x LED light
- 2 x mounting clips and screws
- 1 x end cap
- 1 x set of instructions for assembly, operation and safety

address | contact

A.L.S. GmbH  
Mastorter Str. 31 | 88069 Tettnang (Germany)  
tel.: +49 (0) 75 42 93 44-0 | fax.: +49 (0) 75 42 93 44-30  
E-Mail: info@als.de | Web: www.als.de

	LA (mm)	LB (mm)
4W	285	294
8W	565	574
12W	845	854

The performance of 55W when connecting light bars to each other may not be exceeded. Use new lines (power supplies) for additional lights.

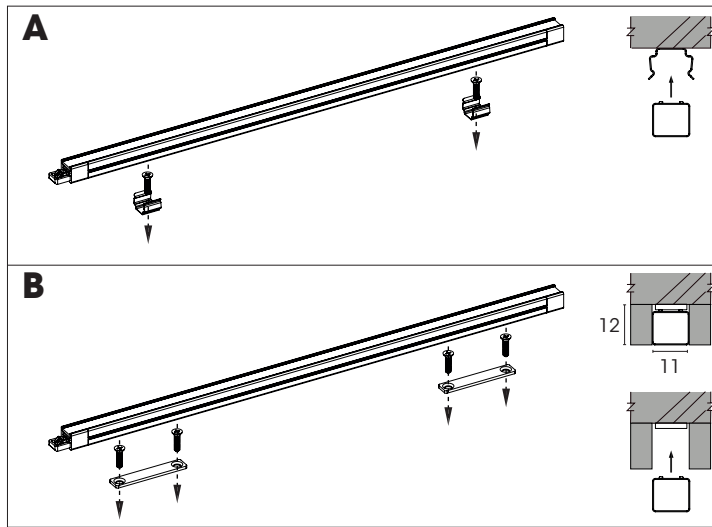

A: Use the supplied terminals for assembly.

B: Optional assembly using set of magnets  
Order Nr. Z-NAHMAG ( 2 steel frames and 4 screws )

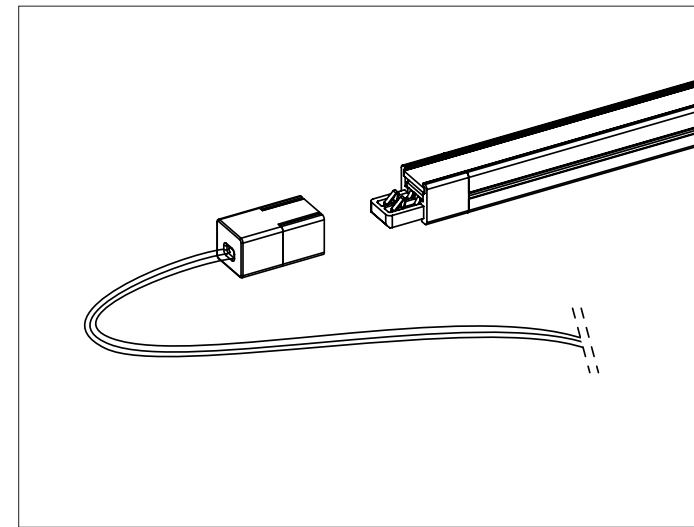

Only the original connection line may be used.

Order Nr. ZUL-NAH200 ( 2000 mm, white )



**Note**  
An LED driver is required for activation of the light.  
See the RECOMMENDED LED DRIVER section of these consumer instructions.

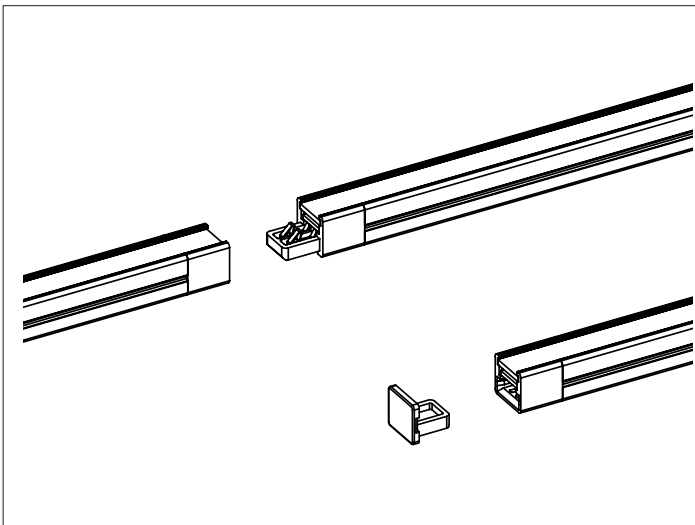

Remove the connection cover for extension. Connect the light bars together using the plug module. Check the plug contacts for fixed connection.

**Note**  
The cover must be placed on the last light in the chain of light bars.

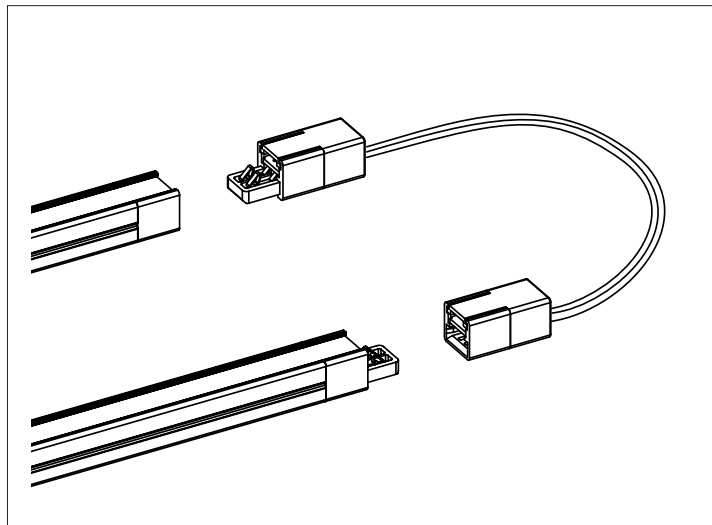

Remove the connection cover. Only use the flexible connections with each other that are intended for the original connection cable. Check the plug contacts for fixed connection.

Order Nr. Z-NAH1501 ( 150 mm, white ) ; Z-NAH6001 ( 600 mm, white )



**Note**  
The cover must be placed on the last light in the chain of light bars.



#### SAFETY



THE LED LIGHTS MAY ONLY CONNECTED TO EACH OTHER, OR REPLACED, WHEN THE ELECTRICITY HAS BEEN TURNED OFF AND USING THE ORIGINAL ELECTRICAL CONNECTORS.

